

TOWARDS A METAHEURISTIC FOR ROUTING ORDER PICKERS IN A WAREHOUSE

C. Theys*

Institute of Transport and Maritime Management
Antwerp (ITMMA)
University of Antwerp, Keizerstraat 64, 2000
Antwerp, Belgium
Email: Christophe.theys@ua.ac.be
Web page : <http://www.itmma.ua.ac.be>

O. Bräysy

Agora Innoroad Laboratory
University of Jyväskylä,
Agora Center, P.O. Box 35, FI-40014, Finland
Email: Olli.Braysy@jyu.fi

W. Dullaert

Institute of Transport and Maritime Management
Antwerp (ITMMA)
University of Antwerp, Keizerstraat 64, 2000
Antwerp, Belgium
Email: Wout.Dullaert@ua.ac.be
Web page : <http://www.itmma.ua.ac.be>

B. Raa

Department of Industrial Management
Ghent University
Technologiepark 903, 9052 Zwijnaarde, Belgium
Email: Birger.Raa@ugent.be

Abstract. In this paper we will deal with the sequencing and routing problem of order pickers in conventional multi-parallel-aisle warehouse systems. For this NP-hard Steiner Travelling Salesman Problem exact algorithms only exist for warehouses with at most three cross aisles. We propose a new approach where the problem of routing order pickers in multiple-block warehouses is translated into a classical Travelling Salesman Problem. Our approach allows for the use of the more powerful (meta)heuristic search procedures developed for amongst others the Vehicle Routing Problem and the Vehicle Routing Problem with Time Windows. To the best of our knowledge, a certain approach has not yet been used in literature on order picking.

Key words: routing, logistics, order picking, warehousing.

1 INTRODUCTION

Order picking refers to the process of collecting stock keeping units from one or more locations in the warehouse as a result of customer orders. Orders from customers are possibly accumulated into batches, which are then assigned to order pickers and pick waves. These pick waves are time windows determining the earliest possible starting time and latest possible finishing time of the picking of all items in a batch. Once batches are formed, sequencing and routing decisions for the order picker have to be made, where the sequence in which the items will be picked and the corresponding route through the warehouse are determined. The final step of the picking process then consists of the sorting of picked batches into customer orders, which can be performed

either during the picking process itself or afterwards. For a recent overview on research on warehouse operations, the reader is referred to Gu et al.^[1]

The order picking process accounts for no less than 55 (Bartholdi and Hackman^[2]) to 65 percent (Coyle et al.^[3]) of the total operational warehouse costs. Furthermore, research has shown that order picking represents up to 60 percent of a warehouse's total job package (Drury et al.^[4]) of which more than 55% is related to travelling (Bartholdi and Hackman^[2]). As such, warehouse design and the efficient assignment and routing of pickers within a warehouse, holds a large potential for cost savings.

Sequencing and routing procedures so far have been analyzed in literature for four types of warehouse systems (see Gu et al.^[1]). The most common type of order picking warehouse system, which will be our focus, is the conventional multi-parallel-aisle system (multiple block warehouse). Other variants are the automated storage and retrieval systems (AS/RS), both the man-on-board AS/RS and the unit-load AS/RS, and the carousel systems. The heuristics developed for the operational process of routing order pickers in multi-block warehouses are simple construction heuristics which construct a feasible solution, without attempting any improvement by means of local search or metaheuristic search. Based on the impressive results obtained by (meta)heuristic search for reducing distance in traditional routing problems such as the Vehicle Routing Problem and the Vehicle Routing Problem with Time Windows, further research on routing order pickers is called for.

This paper reports on how to develop a novel modelling approach for routing and sequencing order pickers in conventional multi-parallel-aisle systems. More specifically, we will reformulate the problem so that existing heuristics for the classical Travelling Salesman Problem (TSP) can easily be modified for this order picking setting. An efficient TSP algorithm will be adjusted to meet the specific features of this routing problem. To the best of our knowledge, we are the first to explore this idea which does not only hold a promise of reduced travel times, but will also open up perspectives for tackling more complicated problems than currently possible with the existing "dedicated" heuristics for routing order pickers.

The remainder of this paper is structured as follows. In the next section a problem description is given and related work is discussed. Section 3 reformulates the sequencing and routing problem of order pickers into a classical Travelling Salesman Problem. Section 4 describes ongoing work on the development of an efficient TSP-based heuristic and testing it against existing order picking heuristics from the literature.

2 PROBLEM DESCRIPTION AND LITERATURE REVIEW

Conventional multi-parallel-aisle warehouse systems have a rectangular layout (Figure 1). They consist of longitudinal aisles with items stored, called pick aisles, and two or more cross aisles perpendicular on the pick aisles. Cross aisles are used to efficiently move from one pick aisle to another and are assumed not to contain any items to be retrieved. The warehouses in this setting consist of one or more blocks. A block is formed by two adjacent cross aisles, with parts of pick aisles in between. These parts of pick aisles are called the block's subaisles. The main decision to be made in the order picking process is designing the route that the picker has to follow on its way through the warehouse, starting and ending at a depot. This depot can either be centrally or decentrally located.

Since the most common objective for order picking routes is to minimize the total distance travelled, the resemblance with the travelling salesman problem (TSP) becomes obvious and has been identified by e.g. Gelders and Heeremans^[5]. More specifically, the specific situation of the routing of order pickers, represented by the graph $G = (N,E)$, classifies as a Steiner travelling salesman problem (Cornuéjols^[6],

Roodbergen^[7]). The aim of the Steiner TSP is finding a minimum-length Steiner tour, where each node $n \in N$ is visited at least once. Since this problem is NP-hard, scientific attention has largely been devoted to finding efficient heuristics to determine an appropriate route. It is striking, however, that until now only construction heuristics have been suggested in the literature.



Figure 1 Warehouse representation

Single-block warehouses (i.e. consisting of two cross aisles only, one at the front and one at the back of the warehouse) have received considerable attention in literature. Ratliff and Rosenthal^[8] propose an exact algorithm for the single-block setting, based on partial tour subgraphs and seven equivalence classes. Besides this exact algorithm, numerous heuristics have been developed for this basic setting and performances compared. The S-shape or Transversal heuristic crosses every pick aisle with items to be picked up entirely, thereby following an S-shaped pattern throughout the warehouse (see e.g. Petersen^[9] and Roodbergen^[7]). Opposed to the procedures of the S-shape heuristic, the Return heuristic returns in each pick aisle that contains order items, so that no single aisle is crossed entirely. The Composite heuristic combines elements from the S-shape and Return heuristics by evaluating whether crossing the aisle entirely or returning generates the shortest distance between the last picked order item and the next one (Petersen^[10]). The Midpoint heuristic first divides the warehouse in two sections by an (artificial) midpoint line. After all items in the upper section of the warehouse have been collected, the procedure is repeated for the lower section. Hall^[11], however, has illustrated that the Largest Gap heuristic under all circumstances performs at least equal to the Midpoint heuristic. The Largest Gap heuristic determines two warehouse sections by calculating for every pick aisle the “largest gap”, which is the largest distance between two items to be picked up in the aisle or an item and an adjacent cross aisle.

Straightforward use of the former algorithms in multiple-block settings is not possible, but the S-shape and Largest Gap heuristics have been modified for warehouses with three or more cross aisles (see Roodbergen^[7]). Other heuristics for multiple-block warehouses include the Aisle-by-aisle heuristic of Vaughan and Petersen^[12] and the Combined heuristic of Roodbergen^[7]. The last two heuristics are based on dynamic programming procedures and compose a route by combining minimum-distance subroutes. The S-shape, Largest Gap and Combined heuristics work on a block-by-block base and retrieve first all items in the upper warehouse block, after which all subsequent blocks will be dealt with separately until one arrives again at the depot. The Aisle-by-aisle heuristic travels through the warehouse based on a different principle,

whereby for every pick aisle all order items are retrieved before moving to the next pick aisle.

Multiple-block routing heuristics are “generalized” order picking algorithms in that they can also be deployed to single-block settings. Note, however, that to date the single-block exact algorithm has only been adapted for use in warehouses consisting of two blocks (see Roodbergen and De Koster^[13]). For larger warehouses no efficient exact algorithms are known. Therefore, Theys et al.^[14] analyzed and compared the performances of the S-shape, Largest Gap, Combined and Aisle-by-aisle heuristics in various multiple-block warehouse situations. They illustrated that the choice of the most appropriate construction heuristic is highly determining on the important relationship between vertical and lateral warehouse dimensions. The Aisle-by-aisle heuristic, which in general was best performing, appeared to be particularly sensitive to changes in vertical warehouse dimensions. The S-shape, Combined and Largest Gap heuristics, on the other hand, were sensitive to changes in the lateral warehouse dimensions.

The order picking process as analysed in this paper is subject to a number of constraints. First, the route is assumed to start and end in a single depot, located in the first cross aisle, either centrally (in the middle of the aisle) or decentrally (anywhere else). De Koster and Van der Poort^[15] relax this assumption and modify the single-block exact algorithm for the situation in which pickers can drop the picked items at the crossing of every pick aisle with the first cross aisle, for instance on a conveyor. Secondly, all aisles are assumed to be of a “normal” width. This means that the distance caused by lateral movements in the aisles is negligible. If this is not the case, we refer to Goetschalckx and Ratliff^[16]. Thirdly, the sequencing and routing computations do not explicitly account for similar products stored at different locations. Daniels et al.^[17] include this problem of multiple storage locations for a single product in their analysis and provide some adapted algorithms to solve it. Finally, the capacity of the order picker is assumed to be sufficient for all necessary items to be picked up in a single tour.

3 REFORMULATION TO TRAVELLING SALESMAN PROBLEM

The Steiner Travelling Salesman Problem of routing order pickers in conventional multi-parallel-aisle warehouse systems can be represented by a graph $G = (N, A)$ with node set $N = S \cup R$ and edge set A . Node subset $R = \{1, \dots, n\} + \{0\}$ contains all n order items that need to be picked up in the warehouse, as well as the depot which is represented by node 0. Node subset $S = \{n+1, \dots, n+p\}$ with Steiner nodes indicates all p “crossing nodes” between two or more aisles, where p equals the product of the number of cross aisles and the number of pick aisles in the warehouse. Edge set $A \subseteq R \times R$ represents all travel possibilities between order items and between order items and the depot.

Figure 2 illustrates the concept by means of a warehouse with five pick aisles and three cross aisles ($p = 15$) where 20 items and the depot location need to be visited ($n = 20$). Node subset $R = \{0, 1, \dots, 19, 20\}$ then contains all nodes that explicitly need to be visited at least once, since they are either an order item or the depot. The Steiner nodes in $S = \{21, 22, \dots, 34, 35\}$ do not necessarily have to be part of an order picker’s route. As a result of the special (rectangular) structure of the warehouse, they might, however, be visited while visiting nodes in R .

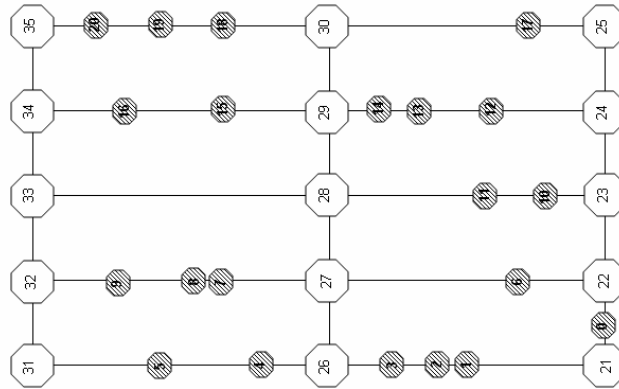

Figure 2 Graph representation of a warehouse

The Steiner Travelling Salesman Problem can now easily be reformulated by calculating the shortest path between any two pickup locations $x, y \in R$ (including the depot). Not only the (symmetrical) distance of the shortest path between x and y , but also its constituting sequence of pickup locations $r \in R$ and Steiner nodes $s \in R$ are maintained.

Since the shortest path between two pickup locations x and y may contain other pickup locations $r \in R$, simply designing a TSP tour based on the distance matrix and route segments obtained from the shortest path calculations could lead to inefficient routes. Moreover, triangle inequality does not always hold and several shortest paths with the same distance but different sequence of nodes may exist, which has to be taken into account in adjusting the TSP algorithm.

4 CONCLUSIONS AND DIRECTIONS FOR FURTHER RESEARCH

In this paper we developed an approach to reformulate the routing and sequencing problem of order pickers in multiple-block warehouses as a classical Travelling Salesman Problem. The next step in our solution procedure is then to apply the powerful Lin-Kernighan Travelling Salesman Heuristic (LKH) to the reformulated order picking problem. Helsgaun^[18] reported that this algorithm has proven to be highly effective and that in a TSP-setting optimal solutions were obtained for all solved problem instances that were at the disposal of the author. Our solution procedure based on the problem reformulation and the use of LKH will further be tested on problem instances given by Theys et al.^[14]. They developed 108 test configurations for each of four sets of warehouse dimensions. The test instances include a central and a decentral depot location, a random and a volume-based storage policy and three different values for the number of pick aisles, cross aisles and order items to be picked up. Applying our solution procedure to their test instances will allow us to evaluate the efficiency of the TSP-based metaheuristic in different warehouse situations.

We expect factors such as the number of pick and cross aisles and the size of the order list to have a particularly large influence on the performance of the metaheuristic search. The more pick and cross aisles one encounters in a warehouse, the more routing possibilities will have to be examined, so that an efficient metaheuristic with powerful search capabilities will clearly have an advantage. Similarly, the more items one needs to collect in a warehouse, the smaller the improvement potential of a metaheuristic in the routing process will be. This is due to the fact that for larger order sizes comparatively more subaisles will have to be crossed entirely. Although our new

solution approach to the routing and sequencing of order pickers in multiple-block warehouses clearly opens new perspectives and possibilities, its use in large-scale real-life situations thus still needs to be considered.

5 REFERENCES

- [1] Gu, J., Goetschalckx, M. and McGinnis, L.F. (2007) Research on warehouse operation: A comprehensive review. *European Journal of Operational Research*, 177 (1), pp 1-21.
- [2] Bartholdi, J.J. and Hackman, S.T. (2006) Warehouse and Distribution Science. Release 0.80. Online available at <http://www.warehouse-science.com>.
- [3] Coyle, J.J., Bardi, E.J. and Langley, C.J. (1996). *The Management of Business Logistics*, West St Paul.
- [4] Drury, J. (1988) Towards more efficient orderpicking. In: *IMM Monographs 1, Institute of Materials Management*, Cranfield, UK, 1988.
- [5] Gelders, L. and Heeremans, D. (1994) *Het travelling salesman probleem toegepast op orderpicking* [in Dutch]. Tijdschrift Economie en Management, 39 (4), pp 381-388.
- [6] Cornuéols, G., Fonlupt, J. and Naddef, D. (1985) The travelling salesman problem on a graph and some related integer polyhedra. *Mathematical Programming*, 33, pp 1-27.
- [7] Roodbergen, K.J. (2001) *Layout and routing methods for warehouses*. Erasmus Universiteit Rotterdam.
- [8] Ratliff, H.D. and Rosenthal, A.S. (1983) Orderpicking in a rectangular warehouse: a solvable case of the travelling salesman problem. *Operations Research*, 31 (3), pp 507-521.
- [9] Petersen, C.G. (1997) An evaluation of order picking routing policies. *International Journal of Operations & Production Management*, 17 (11), pp 1098-1111.
- [10] Petersen, C.G. (1995) Routing and storage policy interaction in order picking operations. *Decision Sciences Institute Proceedings*, pp 1614-1616.
- [11] Hall, R.W. (1993) Distance approximations for routing manual pickers in a warehouse. *IEE Transactions*, 25 (4), pp 76-87.
- [12] Vaughan, T.S. and Petersen, C.G. (1999) The effect of warehouse cross aisles on order picking efficiency. *International Journal of Production Research*, 37 (4), pp 881-897.
- [13] Roodbergen K.J. and De Koster, R. (2001) Routing order pickers in a warehouse with a middle aisle. *European Journal of Operational Research*, 133, pp 32-43.
- [14] Theys, C., Dullaert, W. and Herroelen, W. (2007) Routing order pickers in multiple block warehouses. Proceedings of the BIVÉC-GIBET Transport Research Day, 2007 / Hilferink Pieter [edit.], e.a., Nautilus, pp 10-30.
- [15] De Koster, R. and Van der Poort, E. (1998) Routing orderpickers in a warehouse: a comparison between optimal and heuristic Solutions. *IEE Transactions*, 30 (5), pp 469-480.
- [16] Goetschalckx, M. and Ratliff, H.D. (1988) Orderpicking in an aisle. *IEE Transactions*, 20 (1), pp 53-62.
- [17] Daniels, R.L., Rummel, J.L. and Schantz R. (1998) A model for warehouse picking. *European Journal of Operational Research*, 105 (1), pp 1-17.
- [18] Helsgaun, K. (2000) An effective implementation of the Lin-Kernighan Traveling Salesman Heuristic. *European Journal of Operational Research*, 126 (1), pp 106-130.